

II Name of Components

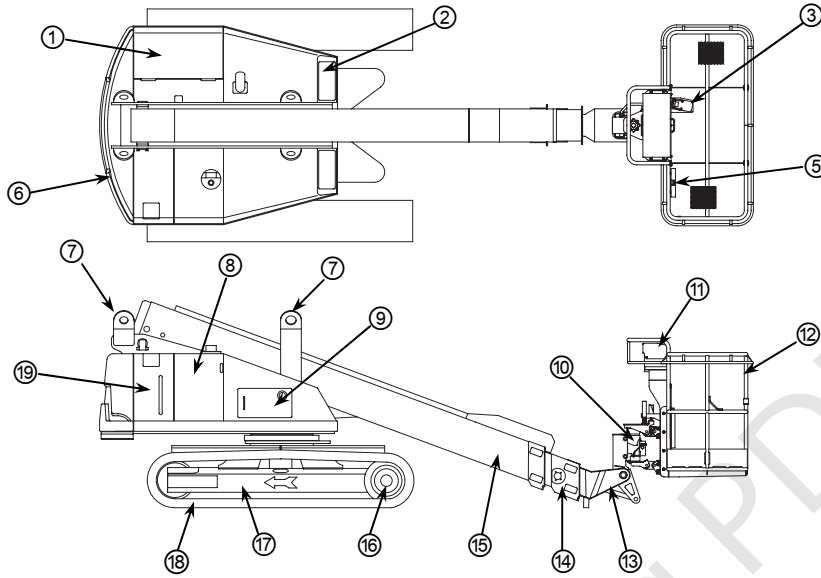

SR12B/ISR40B

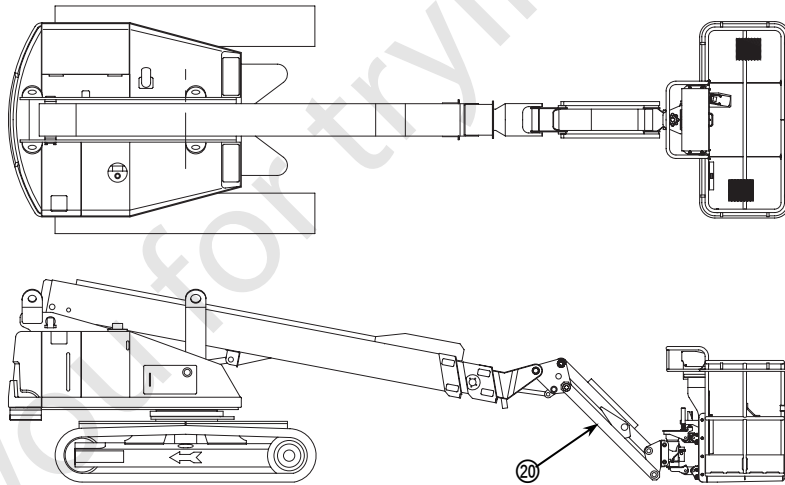

SR12BJ/ISR40J

No.	Name	No.	Name
1	Engine compartment	11	Upper control
2	Rotation lock pin	12	Platform
3	Foot switch	13	3 rd boom section
4	-----	14	2 nd boom section
5	Manual holder	15	1 st boom section
6	Turntable	16	Travel motor
7	Lifting ring	17	Chassis frame
8	Hydraulic oil reservoir	18	Track
9	Lower control	19	Fuel tank
10	Rotary actuator for Platform rotation	20	Fly jib

III Specifications

1. Main specifications

<i>Model</i>		<i>SR12B / ISR40B</i>	<i>SR12BJ / ISR40BJ</i>	
Dimensions	Overall length	6.34 m (20ft – 10in)	7.715m (25ft – 4in)	
	Overall width	2.30 m (7ft – 7in)		
	Overall height	1.995 m (6ft – 7in)		
	Minimum ground clearance	305 mm (12.0 in)		
	Tail swing	0.60 m (2ft – 0in)		
Gross weight		7,445 kg (16,413 LBS)	8,240 kg (18,166 LBS)	
Gradeability		58% (30 degrees)		
Maximum allowable tilt angle		5 degrees		
Maximum ground contact pressure		0.66 kg/cm ² (9.39 PSI)	0.74 kg/cm ² (10.53 PSI)	
Platform	Rated load	250 kg (550 LBS) or 2 persons + Tools 90 kg (200 LBS)		
	Size (L x W x H)	1.8 x 0.75 x 1.1 m (5ft-11in x 2ft-6in x 3ft-7in)		
	Maximum allowable manual side force	400 N (41 kg) (90LBS)		
	Maximum platform floor height	12.1 m (39ft – 8in)		
	Maximum outreach	10.7 m (35ft – 1in)	11.3 m (37ft – 1in)	
	Rotation angle	180 degrees		
Boom	Boom angle	-19 ~ +70 degrees		
	Boom length	4.80 ~ 10.91 m (15ft – 9in ~ 35ft – 10in)	4.80 ~ 9.92 m (15ft – 9in ~ 32ft – 7in)	
	Rotation angle	360 degrees (Continuous)		
Fly jib	Jib angle	-----	-45 ~ +71 degrees	
	Jib length	-----	1.22 m (4ft – 0in)	
Engine	Model	Isuzu 3LD1 PA-49		
	Total displacement	1,496 cc (91 in ³)		
	Maximum output power	21.0 kw/2,400 rpm (28.2 HP/2,400 rpm)		
	Maximum output torque	9.41 kg-m/1,700 rpm (68.1 ft-lbs/1,700 rpm)		
	Fuel tank capacity	95 liters (25.1 gallons)		
	Engine rpm	Low	1,150 rpm	
	High	2,400 rpm		
Battery voltage		DC12 volts		
Actuating speed	Boom elevation	UP	50 seconds	45 seconds
		Down	50 seconds	45 seconds
	Fly jib elevation	Up	-----	20 seconds
		Down	-----	18 seconds
	Boom telescope	Out	25 seconds	23 seconds
		In	25 seconds	23 seconds
	Boom rotation	CW	110 seconds	115 seconds
		CCW	110 seconds	115 seconds
	Platform rotation	CW	11 seconds	
		CCW	11 seconds	
Traveling	High speed	1.5 km/hour (0.93 MPH)		
	Low speed	0.9 km/hour (0.56 MPH)		
Hydraulic system	Rated pressure	250 kg/cm ² (3,556 PSI)		
	Hydraulic tank capacity	145 liters (38.3 gallons)		
	Recommended hydraulic oil	Shell Tellus oil T22		

- * Airborne noise emissions do not exceed a sound pressure level of 85 dB(A) at the operating positions.
- * The vibration emitted by the machine does not exceed 0.5m/s² (19.7 in/s²) on the work platform.
- * This machine is designed for both indoor and outdoor use.

2. Work range diagram

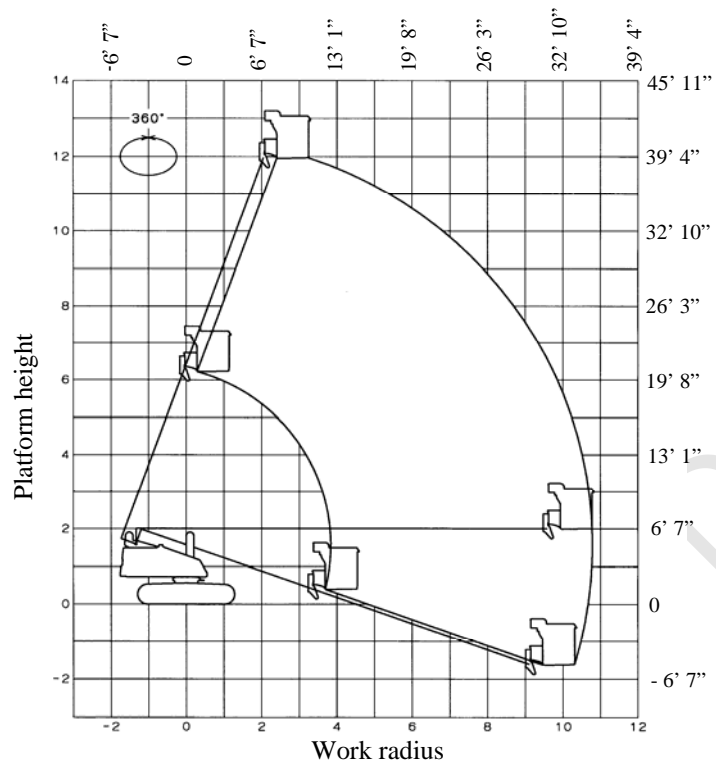

SR12B / ISR40B

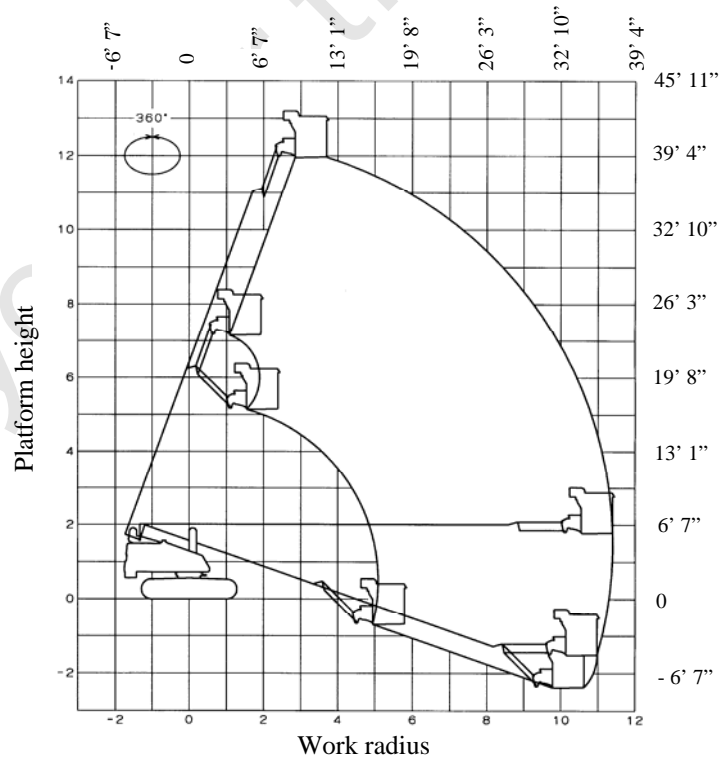

SR12BJ / ISR40BJ

The work range of the platform shown in the above diagram is obtained at any boom-rotated directions.